

### 注意事项

本说明页中所述全部操作都必须且只能由专业人员完成。安装装置时,请关掉所有电压设备以及遵守有关国家安装操作规定。最终用户与/或安装人员需对以下负责,保证:

证系统的电,机械与温度与所安装的框架以及相连接的设备的兼容性。安装轨道时,不可超过文件中所规定的荷载和距离轨道与其配件以及适配器,不可与不带质量标志的部件一起

用。A.A.G.Stucchi的轨道只可以使用的连接件,A.A.G.Stucchi的连接件只能用于A.A.G.Stucchi的轨道A.A.G.Stucchi公司允许只能使用A.A.G.Stucchi的零配件用于ONETRACK®轨道系

统。零配件需要正确地按照安装说明来进行安装。如果使用非原厂的零配件,或者没有符合安装说明,那么作为生产厂家将不对系统的安全性和功能性所负责。这种情况下使用者有责任确保产品和灯具间的电气性,机械性及热容性的相兼容。

轨道将通过A.A.G连接到电源。Stucchi文章9001 / ..和9002 / ...。

严禁使用任何溶剂,胶水,油,油脂或清洁剂与ONETRACK®组件接触。对于因使用上述材料而造成的任何损害,本公司概不负责。

轨道的轮廓中有一把机械钥匙,以保证多段轨道的正确连接。

另外,端部馈电和接头处有一把机械钥匙(螺钉按照以下的图纸来提供),为保证选择正确的部件,需考虑到这点。

机械钥匙所在的位置以红线标注。

### WARNING

All the described operations of this instructions page must be performed by qualified personnel only. Disconnect power during installation or servicing. Please respect national and local installation regulations. A.A.G. Stucchi allows the use of A.A.G. Stucchi parts only in applications where the ONETRACK® system is used. These parts must be installed according to the installation instructions. The company as a manufacturer is not responsible for the safety and functionality of the system if parts not belonging to it are used or if there are any deviations from the installation instructions. It is then the user's responsibility to ensure the electrical, mechanical and thermal compatibility between the system and the fixtures used with it. The track, its components and also the adapters can't be used with accessories without the appropriate approvals.

On A.A.G. Stucchi track one can use only A.A.G. Stucchi connections. A.A.G. Stucchi connections can be used only with A.A.G. Stucchi tracks.

The track is to be connected to electrical power by means of the A.A.G. Stucchi articles 9001/.. and 9002/...

It is strictly forbidden to use any kind of solvent, glue, oil, grease or cleaner in contact with ONETRACK® components. The company is not responsible of any damage caused by the use of the materials mentioned above.

There a mechanical key on the track to guarantee the proper connection of multiple pieces of track. This key is present on all end-feeds and connecting components (see screw below-pictured). Care must be taken when ordering to select the correct components. The catalog drawing depict the position of the key with a red line.

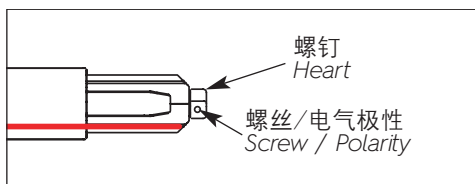

标准版/嵌入式版  
Standard / recessed track

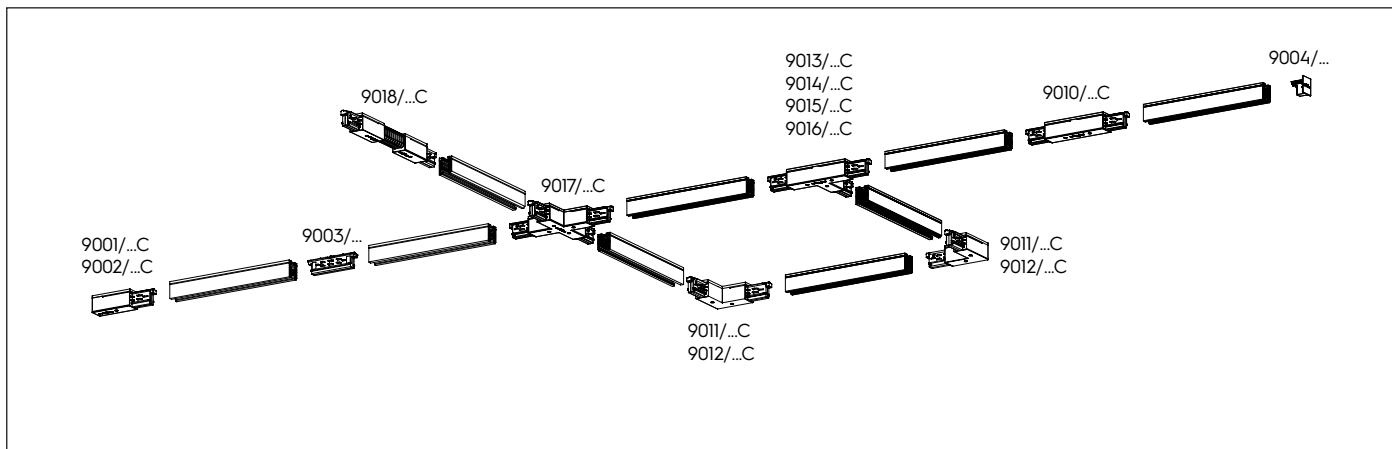

H型轨道  
H track

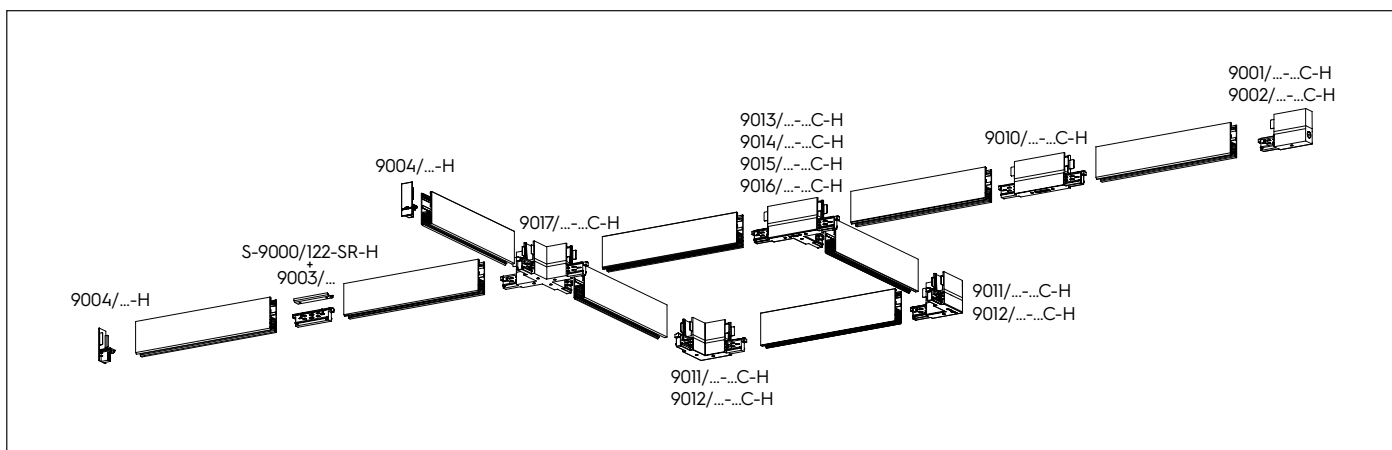

无需微调跟踪  
Trimless track

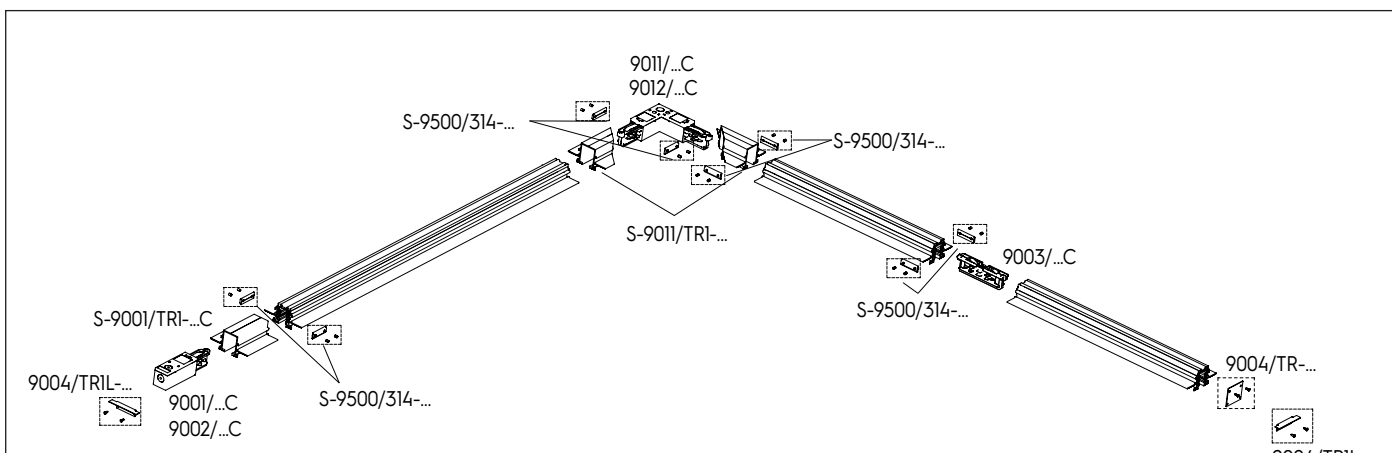

A.A.G. Stucchi OneTrack®系统为三相混合系统，具有两根附加导体，用于管理普通数据信号(例如，dali、dmx、lon、eib等)。该系统通过了EN 60570认证，安装时必须由具备较高资质的人员在场。  
不超过最大负载。  
进行电路连接时必须遵守图2的接线方案。

A.A.G. Stucchi OneTrack® system is a 3 phase mixed system with two additional conductors intended to manage a general data signal (for example dali, dmx, lon, eib, etc). The system is in the proces to be EN 60570 certified and its installation must be accomplished by highly qualified person without exceeding the maximum loads (see pics). During the wiring the electrical the scheme of picture 2 must be followed.

**三相导轨 + 控制系统:  
9000-.../...-ST或9000-.../...-R**

**THREE-PHASE TRACK + CONTROL SYSTEM:  
9000-.../...-ST AND 9000-.../...-R**

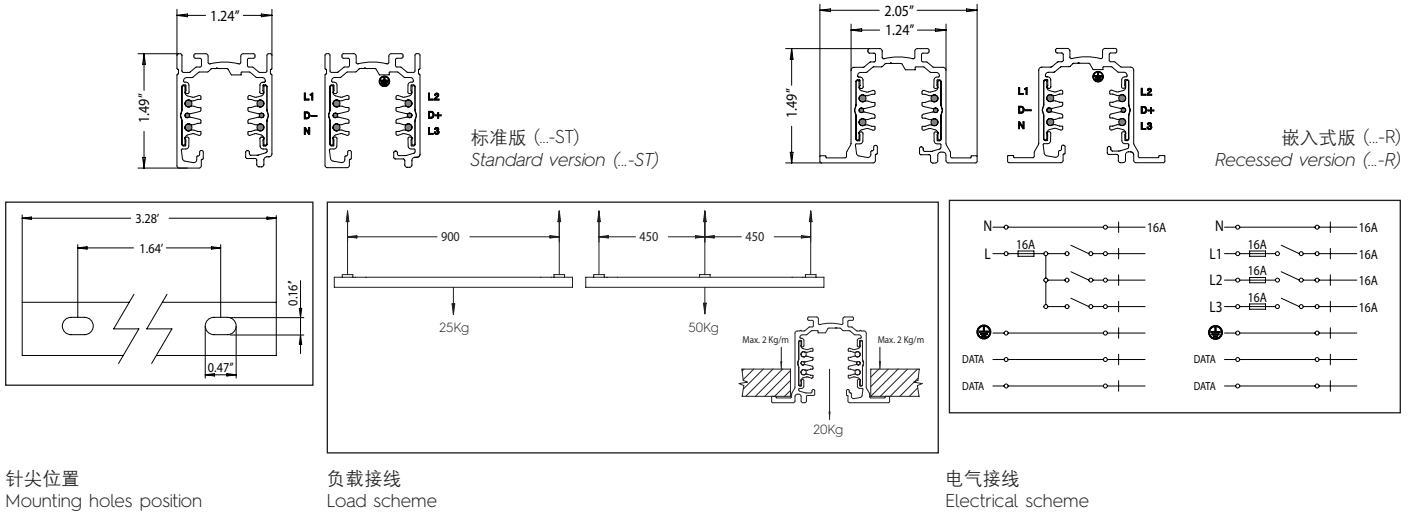

**三相导轨 + 控制系统:  
9000-.../...-H**

**THREE-PHASE TRACK + CONTROL SYSTEM:  
9000-.../...-H**

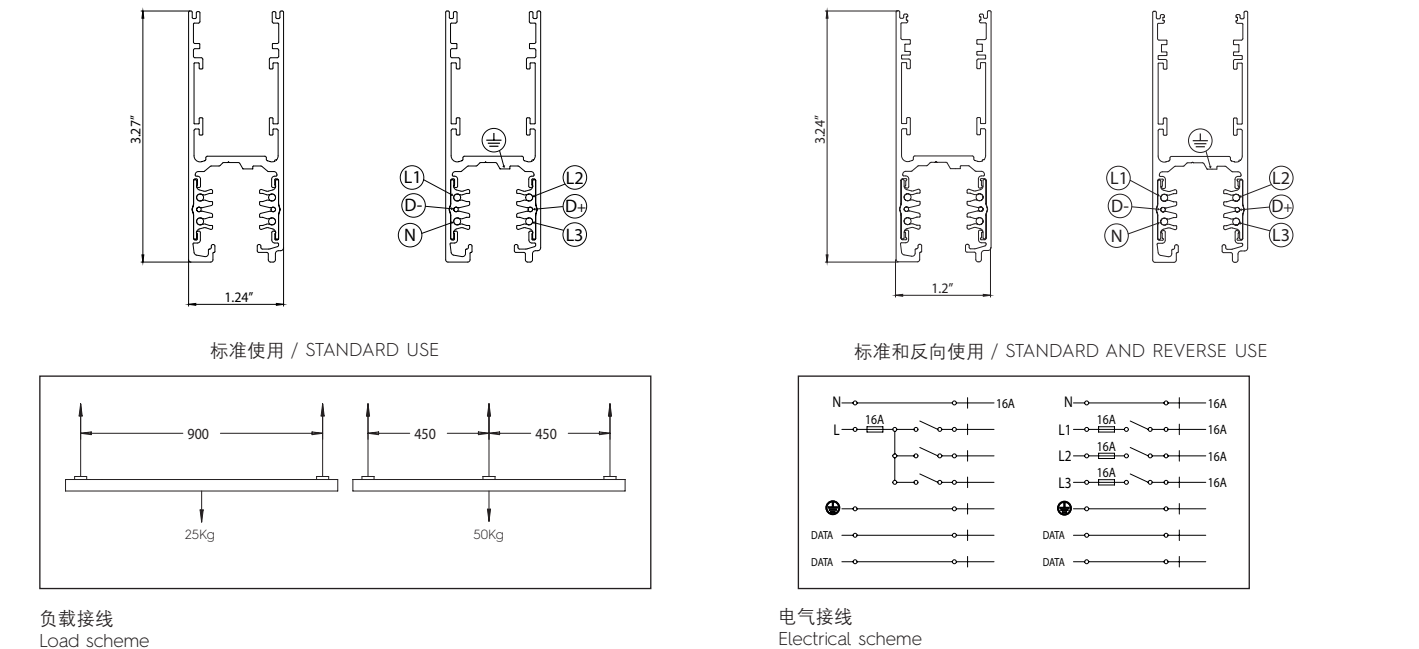

三相导轨 + 控制系统:  
9000-.../...-TR

THREE-PHASE TRACK + CONTROL SYSTEM:  
9000-.../...-TR

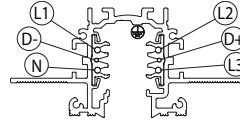
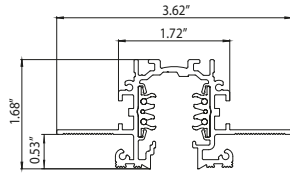

版本无边 (...TR)  
Standard trimless (...TR)

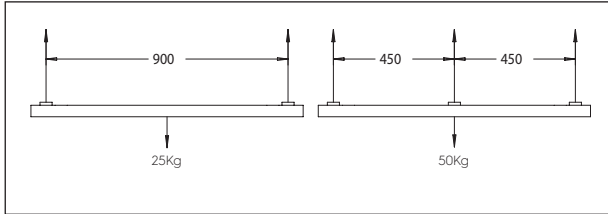

负载接线  
Load scheme

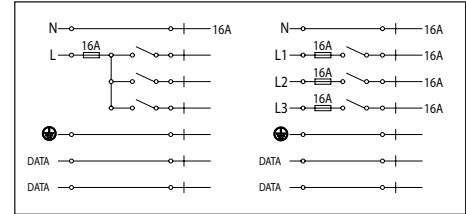

电气接线  
Electrical scheme

长度为1-2-3-4米的导轨条已内嵌有铜导体，符合相关安全标准。

如果安装过程中需要缩短导轨则必须在切割后使用专用切刀 (S-9000/T带...ST, ...R, ...H-S-9000/T-TR带...TR) 将4根导体 (L1-L2-L3-N) 嵌入至少5毫米，以遵守正确的空气、表面和电距离 (图4和5)。

The track bars with length 1-2-3-4 m are provided with the copper conductors already recessed, in compliance with the relevant safety standard. If it is necessary to shorten the track during installation, after the cut it is necessary to use the special cutting tool (S-9000/T with ...ST, ...R, ...H - S-9000/T-TR with ...TR) to recess the 4 conductors (L1-L2-L3-N) at least of 5mm so that the correct air, surface and electrical distances are respected (pic. 4 and 5).



图4 嵌入导体  
Pic. 4 Recessing track conductors



图5 最小嵌入深度  
Pic. 5 Minimum recessing

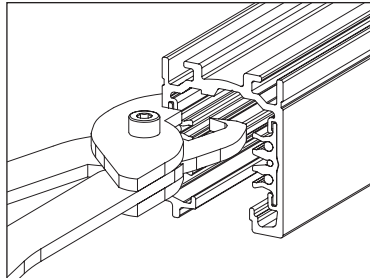

### 警告!

只有正确执行本说明书，才能保证产品的安全、正确使用。所有的操作说明均应保存，以备日后参考。

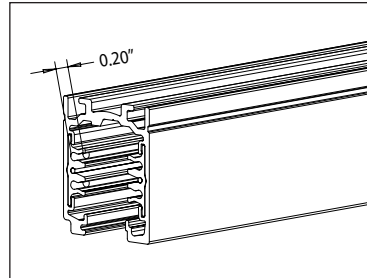
### WARNING!

The safe and correct operation of the product can only be guaranteed when these instructions are followed correctly. All instruction should be kept for future reference.

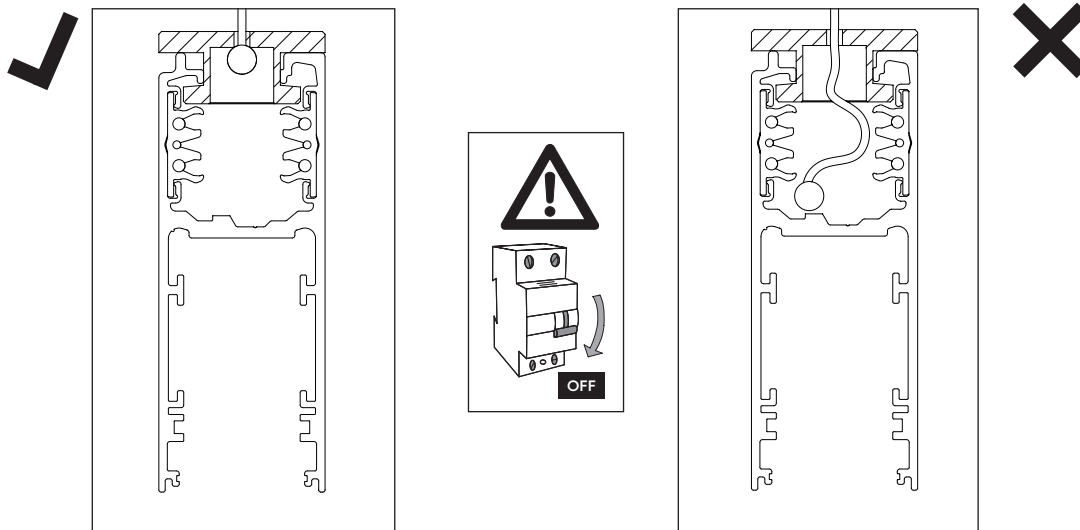

请勿将任何导电材料(金属或其他)插入导轨内。这样做会造成触电的危险。

DO NOT INSERT ANY CONDUCTIVE MATERIAL (metal or otherwise) into the track. Doing so creates an Electrical Shock Hazard.

