

警告

本说明页中所述全部操作都必须且只能由专业人员完成。安装装置时,请关掉所有电压设备以及遵守有关国家安装操作规定。最终用户与/或安装人员需对以下负责,保证:保证系统的电,机械与温度与所安装的框架以及相连接的设备的兼容性。安装轨道时,不可超过文件中所规定的荷载和距离轨道与其配件以及适配器,不可与不带质量标志的部件一起用。A.A.G. Stucchi的轨道只可以使用的连接件,A.A.G. Stucchi的连接件只能用于A.A.G. Stucchi的轨道。A.A.G. Stucchi公司允许只能使用A.A.G. Stucchi的零配件用于MULTISYSTEM®/MULTISYSTEM® EVO轨道系统。零配件需要正确地按照安装说明来进行安装。如果使用非原厂的零配件,或者没有符合安装说明,那么作为生产厂家将不对系统的安全性和功能性所负责。这种情况下使用者有责任确保产品和灯具间的电气性,机械性及热容性的相兼容。该跟踪系统是 III 级标准系统,和其他制造商的 I 级或 III 级跟踪系统并不兼容。为避免电路短路和过载,请插入合适的电源电路保护装置。

产品和安装的安全警告

- 严禁使用NON SELV或U-OUT > 60V直流电源,驱动器和组件。

A.A.G. Stucchi建议使用兼容光电隔离的中继器(例如RP-DALI-24-48V)。

- 您可以选择在2种不同模式下使用轨道的4根导线:
 - 2种不同的电源(2个电路,0 - 60V dc)
 - 1个用于60V dc的电路和1个用于数据总线的电路

如果您想在您的照明项目(建筑,商店等)中创建一个独特的数据总线,将低压轨道数据总线与其他照明应用的数据总线电气连接,所有相关组件必须经过SELV批准。

严禁使用与MULTISYSTEM®/MULTISYSTEM® EVO组件接触的任何溶剂,胶水,油,油脂或清洁剂。对于因使用上述材料而造成的任何损害,本公司概不负责。

WARNING

All the operations must be done by specialized personnel only, shutting of the electrical power and respecting all national installation regulations and guidelines. A.A.G. Stucchi allows the use of only A.A.G. Stucchi parts in applications where the MULTISYSTEM®/ MULTISYSTEM® EVO system is installed. These parts must be installed according to the installation instructions. The company as a manufacturer is not responsible for the safety and functioning of the MULTISYSTEM®/ MULTISYSTEM® EVO system if components not belonging to it are used or if there are any deviations from the installation instructions. It is then the third-party manufacturer's responsibility to ensure the correct functionality and the electrical, electromechanical, electronic, mechanical and thermal compatibility between the MULTISYSTEM®/ MULTISYSTEM® EVO system and any other third-party products that are used or even developed for the system itself (i.e. drivers/fixtures). The track, its components and also the adapters can't be used with accessories without the Quality/ Approval Mark of the region. On A.A.G. Stucchi track one can use only A.A.G. Stucchi connections. A.A.G. Stucchi connections can be used only with A.A.G. Stucchi tracks. This track system is Class III and is not compatible with Class I track systems or Class III track systems from other manufacturers. Insert the appropriate power circuit protections in order to prevent short circuits or overloads.

Safety warnings for products and installation

- The use of NON SELV or U-OUT > 60V dc power supplies, drivers and components is strictly forbidden.

A.A.G. Stucchi recommends the usage of an opto-insulated repeater dali compatible (es. RP-DALI-24-48V).

- You can choose to use the 4 conductors of the track in 2 different modes:
 - 2 different power supplies (2 circuits, 0 - 60V dc)
 - 1 circuit for 60V dc and 1 circuit for Data Bus

If you want to create a unique Data Bus in your lighting project (building, shop, etc.), electrically connecting the low voltage track Data Bus with the Data Bus of other lighting applications, all the components involved must be SELV approved.

It is strictly forbidden to use any kind of solvent, glue, oil, grease or cleaner in contact with MULTISYSTEM® components. The company is not responsible of any damage caused by the use of the materials mentioned above.



MULTISYSTEM® 轨道

MULTISYSTEM® EVO TRACK



图 1
Pic. 1

MULTISYSTEM® EVO 轨道是一种 CLASS III (SELV) 等级的轨道。

电源电压必须在 0 到 60Vdc 之间，电源电流不能超过 15A。

室温必须是 25° C，且工作温度不能超过 70° C。

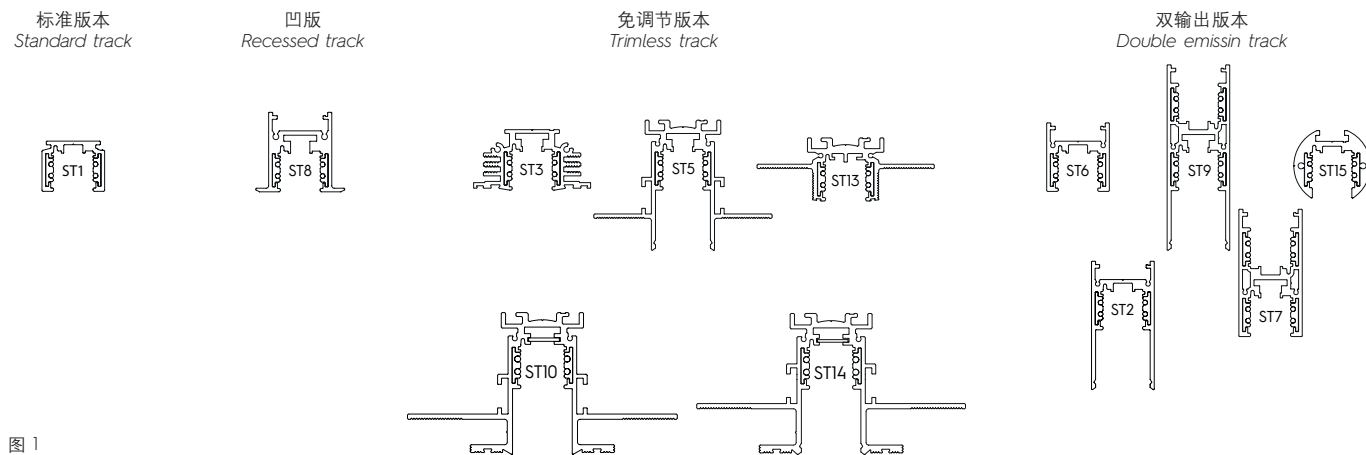
可使用 4 条轨道导线获得两条独立的电源线路，或者一条电源回路和一条数据总线回路。

禁止使用电源适配器、驱动器、数据总线系统、未经认可的 SELV 组件和/或其 U-OUT 大于 60Vdc 的组件。

如果在同一安装项目中，需要将低压轨道的数据总线 and 照明装置的数据总线以电气形式连接起来，从而创建一个唯一的数据总线，其要求使用的所有组件都必须是 SELV 等级的。

且不得超过规定的最大载荷（图 2）。

针对在假平顶上的安装，请遵守该结构的载荷。

所有轨道都有一个机械钥匙（图 3），电气附件分为极化和非极化版本。在安装过程中，仅有那些需要极化的照明灯具才需要遵守极化规定。

The MULTISYSTEM® EVO track is a Class III - SELV product. The supply voltage must be between 0 and 60 VDC and the supply current must not exceed 15 A. The room temperature must be 25°C, while the operating temperature must not exceed 70°C. The 4 track conductors can be used to create two separate power supply circuits, or one circuit for the power supply and one for the DATA BUS. It is forbidden to use control gear, drivers, DATA BUS systems and components that are not SELV-approved and/or with U-OUT greater than 60 VDC.

If in an installation the track system is being integrated with a larger lighting control system by electrically merging the DATA BUS of the low-voltage track with that of other lightfittings, all components used must be SELV-approved.

Do not exceed the maximum loads specified (Pic. 2). When installing the fitting in false ceilings, comply with the maximum load-bearing capacity of the relevant structure.

All tracks come with a mechanical key (Pic. 3); the electrical accessories are supplied in both the polarised and non-polarised versions. During assembly operations, respect the polarity only for the light fittings that require it.



图2 负载图
Pic. 2 Load scheme



图3 极性
Pic. 3 Polarity

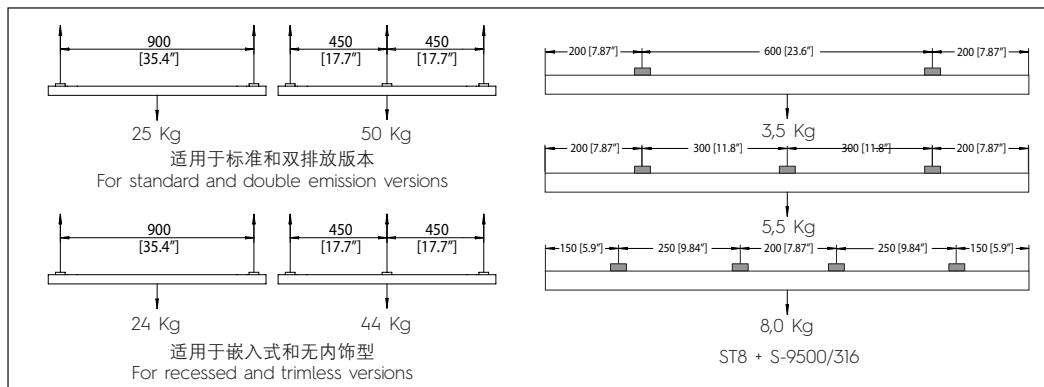

1-2-3 米长的轨道杆均配有已经裁剪而略短于铝杆的铜导线，这是为了在双电源的情况下防止铜电线之间的相互接触，或者在使用封盖的情况下防止铜电线与封盖本身接触。如果在安装过程中需要缩短轨道，在切割后，请使用专用钳子（S-9000 / T）裁剪轨道的 4 根铜导线（图 4），同时注意取下剪切掉的 4 根铜线段（图 5）。然后按照本说明书中的指导，继续安装另一根轨道或加装封盖。

The track bars with 1-2-3 m length are supplied with the copper wires already recessed with respect to the aluminium, to prevent them from coming into contact with one another in case of dual power supply, or, if end caps are used, to prevent the copper wires from coming into contact with them. If the track must be shortened during installation, after cutting it use the special pliers (S-9000/T) to cut back the 4 copper wires of the track (Pic. 4). Make sure to eliminate the 4 pieces of copper wire cut (Pic. 5). Proceed with the installation of another track or apply the end caps, as explained in this instruction sheet.

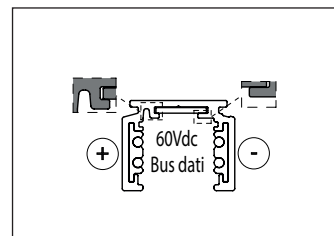

图 4
Pic. 4



图 5
Pic. 5

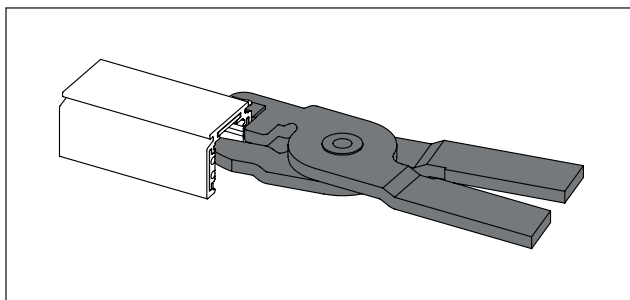
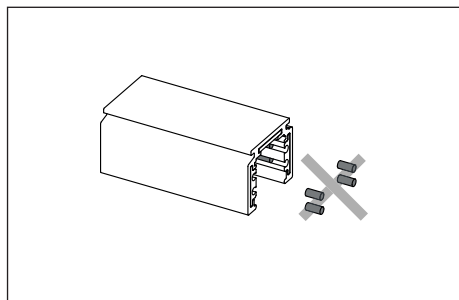