

HSB125

STAFFA METALLICA LUNGA CON MOLLA PER FISSAGGIO DISSIPATORE NEL CONTROSOFFITTO LONG RECESSED MOUNTING METAL BRACKET WITH SPRING

Dati tecnici

Technical data

Caratteristiche

Characteristics

Fornito con vite 567/F (max. momento torcente 1,2Nm)

Supplied with 567/F screw (max. torque: 1,2Nm)

– Staffa in acciaio zincato
– Zinc plated steel bracket

– Molla in acciaio zincato
– Zinc plated steel spring

– Max. carico: 10N
– Max. load: 10N

– Altezza minima di montaggio: angolo utile minimo 60°
– Min. mounting high: min angle of mounted bracket 60°

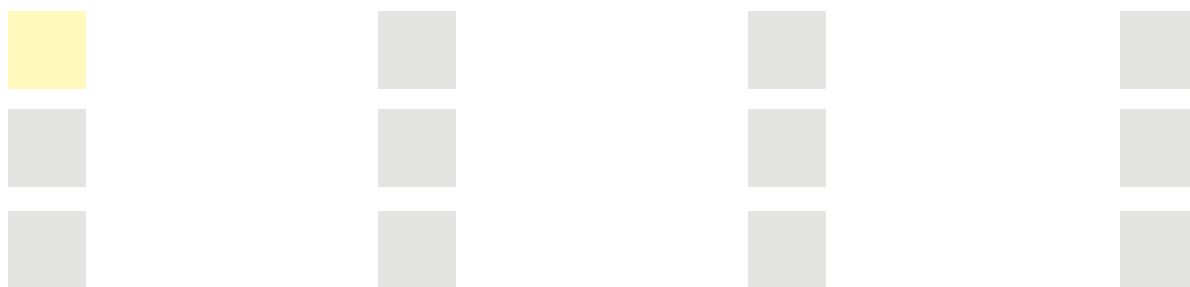
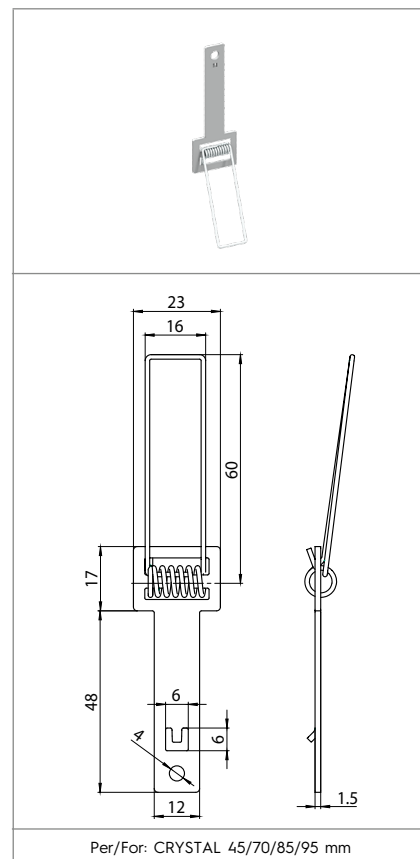

Marchi di qualità

Quality marks

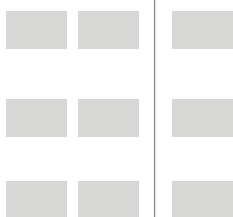

Direttive Europee

European directives

Conforme "RoHS"

"RoHS" compliant

Non soggetto alla "RAEE"

Not subject to "WEEE"

Pesi e confezioni

Weights and packaging

Art. Codice prodotti Product references	g Peso netto Net weight	n° pz per sacco per bag	n° pz per scatola per box	n° pz per cartone per carton
HSB125	11,3	50		

Note

Notes

ISTRUZIONI DI MONTAGGIO ACCESSORI CRYSTAL
MOUNTING INSTRUCTIONS CRYSTAL ACCESSORIES

Bloccacavo (HC18/N)
Cable holder (HC18/N)

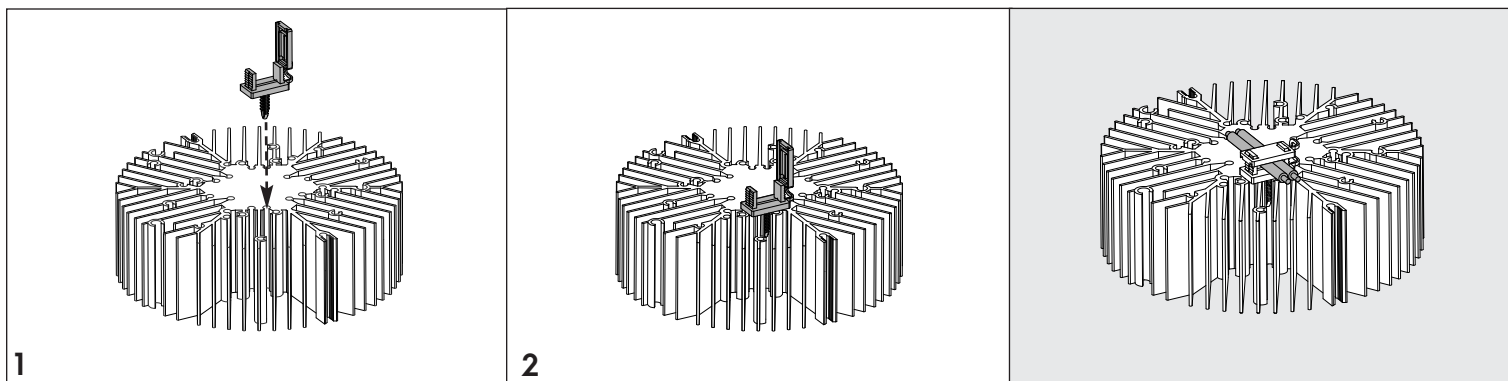

Staffa plastica (HB5/N - HB10/N)
Plastic bracket (HB5/N - HB10/N)

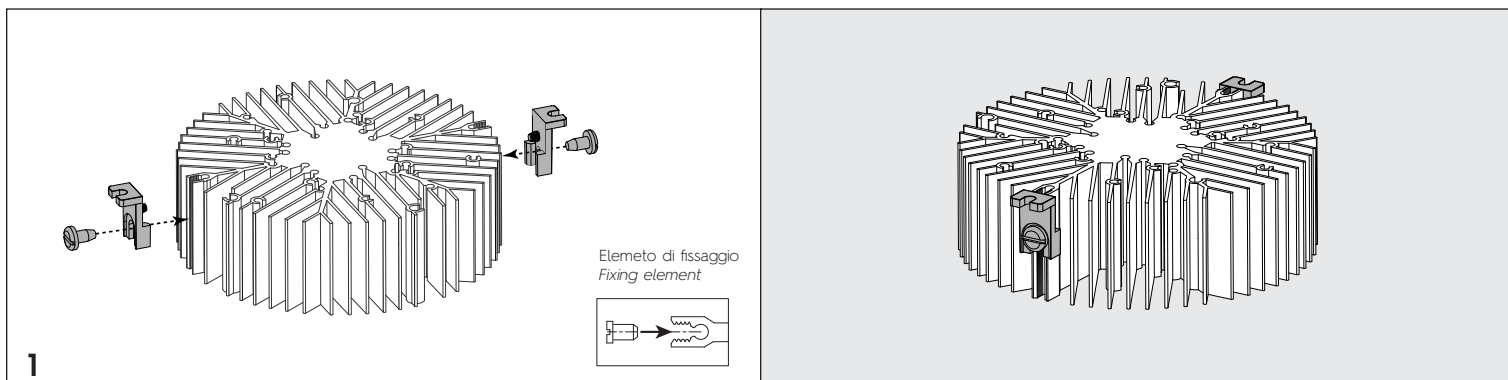

Staffa in metallo con molla (HSB90 - HSB125)
Metallic bracket with spring (HSB90 - HSB125)

